

# Digitalization & Artificial Intelligence in BH

Alessandro Bettini

November 28, 2023

# BH Florence Energy Park

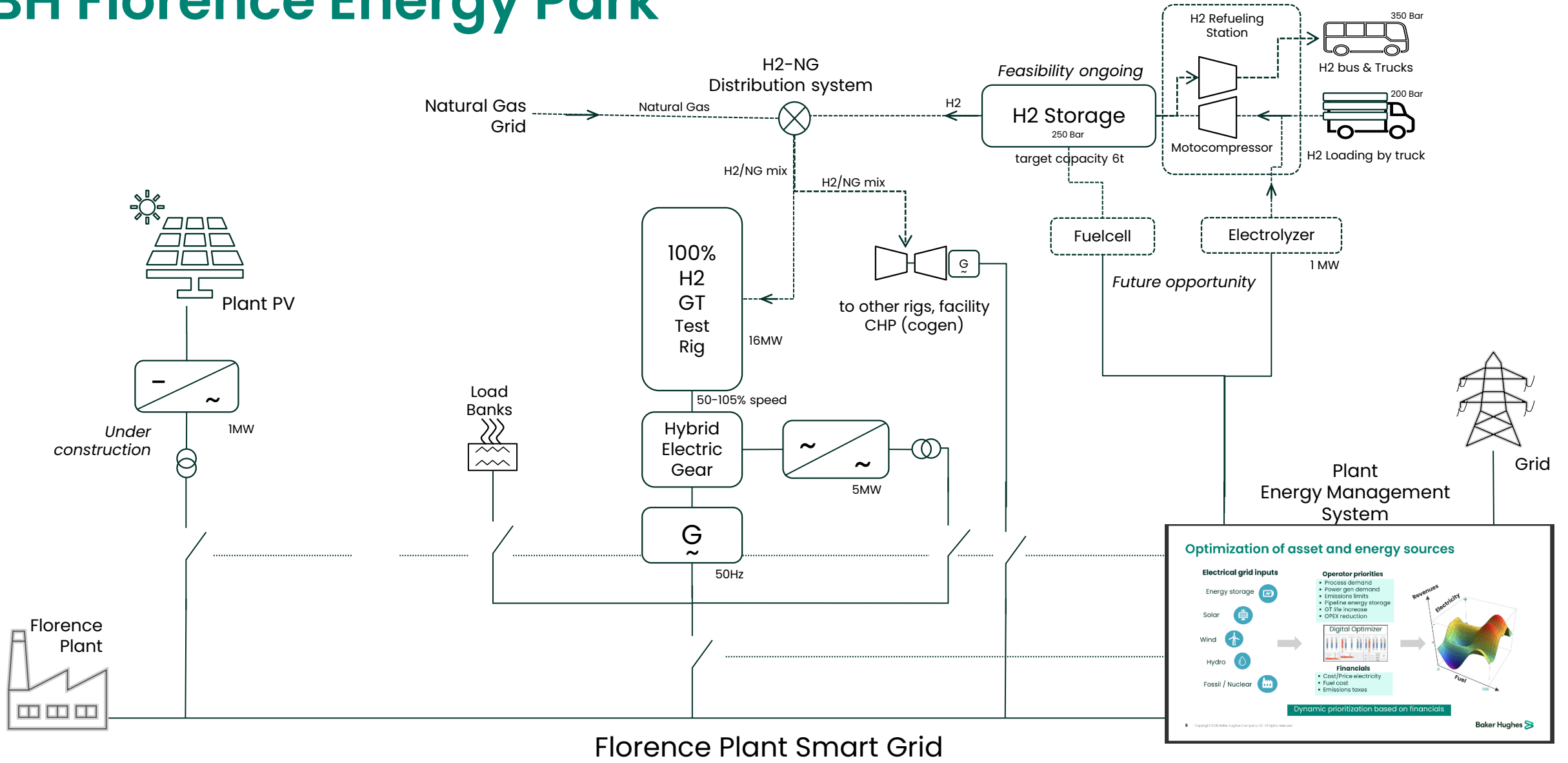

# Robotic Inspections

**Baker Hughes** | Robot Fleet Manager

Welcome to Robot Fleet Manager!  
Optimize, Automate, Excel. Unleash the Power of Robot Fleet Management.

### All Robots

Robot #1	Robot #2
Battery: 85.0 Type: ANYbot State: walking Mission: running	Battery: 38.0 Type: ANYbot State: alighting Mission: stopped

## What is it?

Use robotics and computer vision to perform autonomous inspections at the Technical Training Academy demo skid

## Requirements

The customer wants the robot to perform autonomously the inspection tasks, collect results and share insights

## Results

- Quadruped robot can navigate the environment
- It can collect videos, pictures, audio and thermal images
- The robotic platform is able to collect inspection data, interpret them, and share insights

**Baker Hughes** 